bigstone

C800-TFT Instructions

Nanjing Bigstone Electronic & Technology co.,Ltd

CONTENT

ABOUT THE USER MANUAL	2
OUTLOOK AND SIZE	2
MATERIAL AND COLOR	2
BUTTON DEFINITION	3
FUNCTION SUMMARY	4
FUNCTION SUMMARY.....	4
FULL VIEW AREA.....	5
NORMAL VIEW AREA.....	6
NORMAL OPERATION	6
1. ON/OFF.....	6
2. RIDING MODE SELECTION.....	7
3. SPEED DISPLAY.....	7
4. KM/H & MPH.....	7
5. LIGHT INDICATOR.....	7
6. 6KM/H WORK.....	7
7. PAS LEVEL SELECTION.....	8
8. ERROR CODE INDICATOR.....	8
9. BATTERY INDICATOR.....	8
10. SETTING OPERATION.....	9
11. AUTO SLEEP AFTER	5
MINUTES.....	15
COMMON PROBLEMS & SOLUTIONS	16
QUALITY & WARRANTY	16
QUALITY & WARRANTY.....	16
OTHER ITEMS	16
ERROR CODE TABLE	17

ABOUT THE USER MANUAL

Dear users

To ensure better performance of your e-bike, please read through the C800 product introduction carefully before using it. We will inform you all the details concisely (including hardware installation, setting and normal use of the display) when using our display. Meanwhile, the introduction will also help you solve possible confusion and malfunction.

OUTLOOK AND SIZE

MATERIAL AND COLOR

C800 products are made of black metal material and the bracket is made of nylon material. Under the temperature of -20 to 60℃, the shell material can ensure normal usage and good mechanical performance of the products.

Dimension figure (unit: mm)

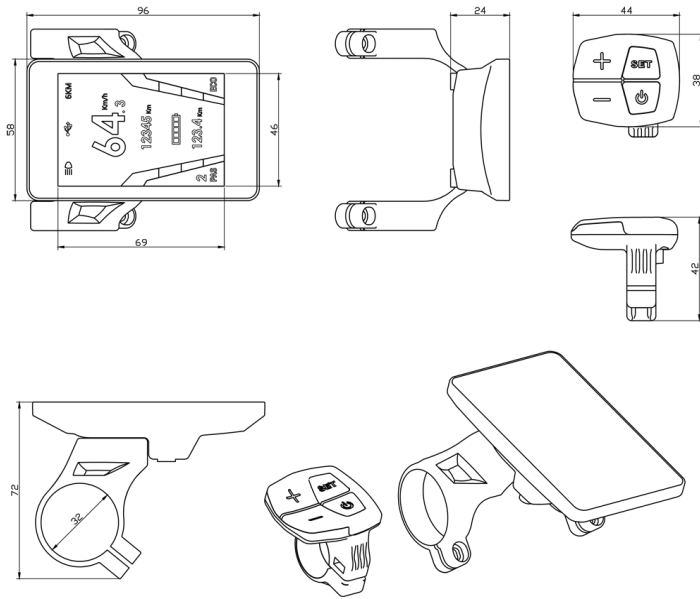

BUTTON DEFINITION

C800 has four buttons including **ON/OFF** , **SET** , **UP** and **DOWN**.

“ON/OFF” names to “”, “SET” names to “**SET**”;“UP” names to “ + ” and “DOWN” names to “ - ”.

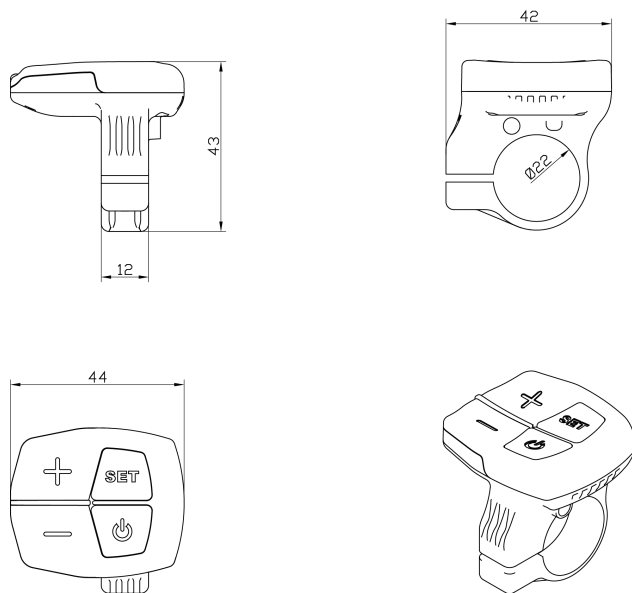

FUNCTION SUMMARY

FUNCTION SUMMARY

C800 provides a wide range of functions and indicators to fit the users' needs. The indicated contents are as below.

1. Riding mode selection
2. Speed display
3. KM/H & MPH
4. Light indicator
5. 6KM/H work
6. PAS level selection
7. Error code indicator
8. Total distance (ODO) and Trip
9. Battery capacity

FULL VIEW AREA



NORMAL VIEW AREA

With the display on ,the default display are riding speed、 trip distance、 ODO、 PAS level、 battery indicator as show in fig below.

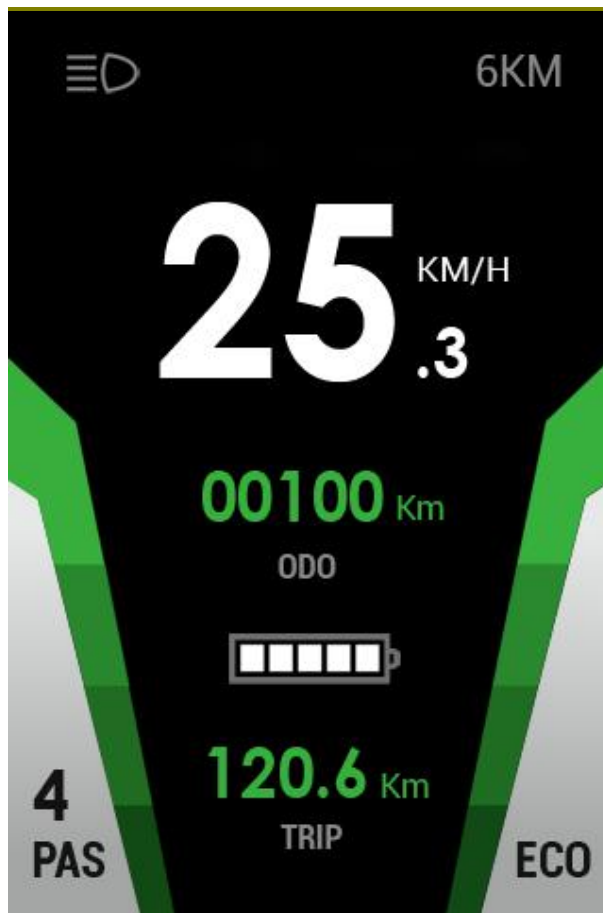

NORMAL OPERATION

1. ON/OFF

Hold **ON/OFF** and start the display. The display will provide power for the controller. Hold **ON/OFF** again can open the light. With display on, press **ON/OFF** for 3 seconds to turn off the power. With the display off, there is no battery consumption battery power. The leakage current is no more than $2\mu\text{A}$.

2. RIDING MODE SELECTION

There are three modes for riding with arrow selection, including POWER, STD and ECO. The default option is NORMAL.

ECO: limited current is about 6A, it is suitable for elderly.

STD: limited current is about 10A, it is suitable for riding in city.

ECO: limited current is about 15A, it is suitable for young and Mountain bike.

3. SPEED DISPLAY

The speed display is as below, and user can select KM/H or MPH in

4. KM/H & MPH

Select KM/H or MPH for the speed and mileage, display will be to the currently selected units display.

5. LIGHT INDICATOR

With the power on, click the **ON/OFF** and turn on the light of bike. Click it again and turn off the light.

6. 6KM/H WORK

Hold the **DOWN** for 2 seconds to get in 6km PAS work, and with your hand off, the 6km PAS work is released.

7. PAS LEVEL SELECTION

Click **UP** or **DOWN** to change the stages and output power ratio, the default mode is mode 5 and it's output power range from level 1 to level 5 (mode 3、 mode 6 and mode 9 can be customized, details in advance setting), the default value is level 1.

8. ERROR CODE INDICATOR

If there is something wrong with the electronic control system, the error code and error message will display in the top of screen. See the last page **Error code table** for details.

※ Display return to normal only after problem being fixed and e-bike will not run before fixing the problem.

9. BATTERY INDICATOR

9.1 Battery residual capacity indicator

The battery frame have five segments, each segment represent 20% battery capacity. When the battery capacity is full, the five battery segments are all light. In low battery, the outside edge of the battery frame will flash. It indicates that the battery is severely low and needs to be recharged immediately.

※See the picture for above messages in Full View Area .

10. SETTING OPERATION

Hold the **SET** for 2 seconds and enter into the setting interface, click “+” “-” to select the setting item, then click **SET** again, when the color of the setting item turns green, then user can press “+” or “-” to select the wanted parameter, and after the parameters have been changed, click **SET** again, the color will turn white and this setting item has been finished.

10.1: Trip Clear

N means NO, Y means YES. Select “Y” and when user return main interface, user will find the **Trip** has been cleared.

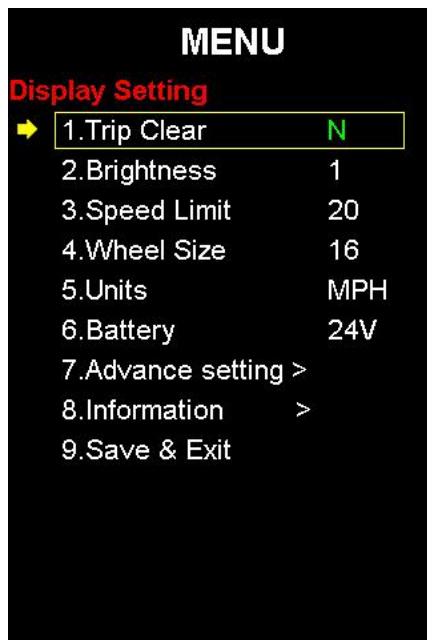

10.2: Brightness

Click “+”, “-” to change the level, 1 means the darkest, 5 means the brightest.

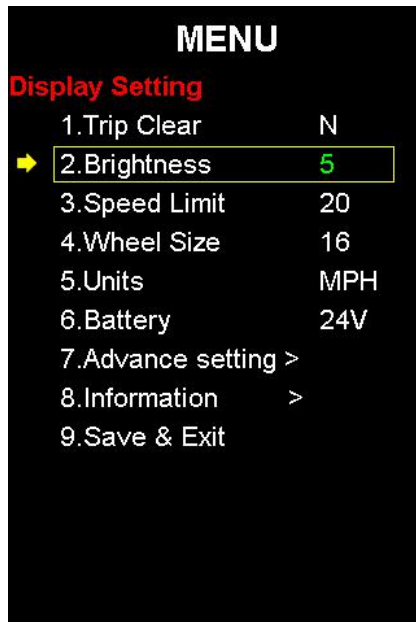

10.3: Speed Limit

The max speed is 99.9 km/h for the default, user can modify the value of max speed, when the riding speed exceeds the set value, the controller will limit the speed to set value, in order to ensure the safety of rider.

※ The max speed value range from 20 km/h to 99.9 km/h. When set max speed 99.9 km/h, there is no limit for riding speed.

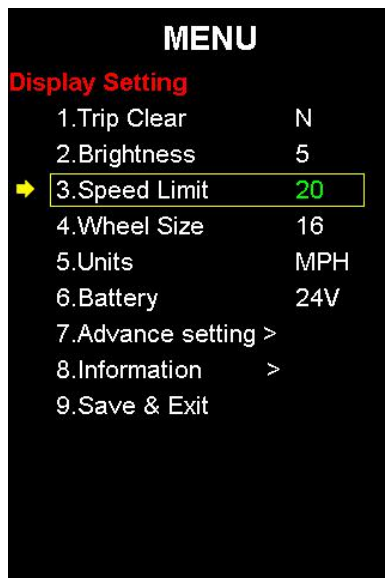

10.4: Wheel Size

Select the suitable value to ensure the accuracy of display about speed and mileage.

The set value can be 16, 20, 24, 26, 700C, 28 (unit: inch)

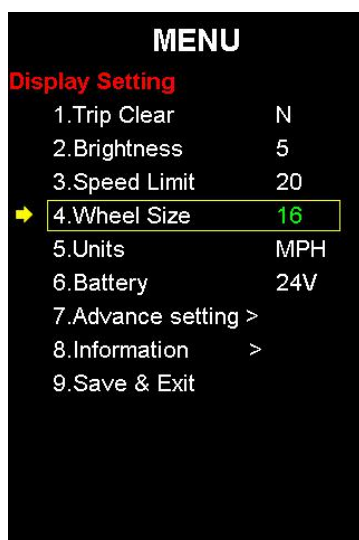

10.5: Units: KM/H & MPH

Select MPH or KMH for the speed and mileage, display will be the currently selected units display.

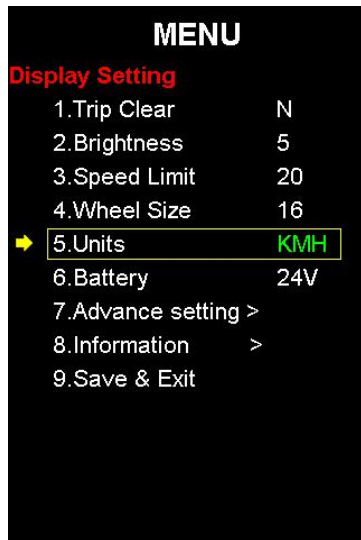

10.6: Battery

The battery voltage can be set to 24V, 36V or 48V. This parameter need to be consistent with the actual parameter of user's e-bike.

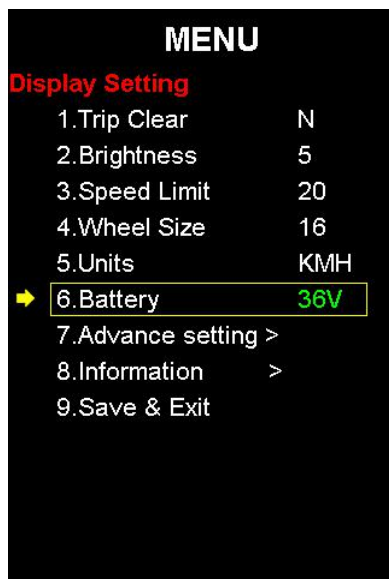

10.7: Advance setting

Click **SET** to enter advance setting interface.

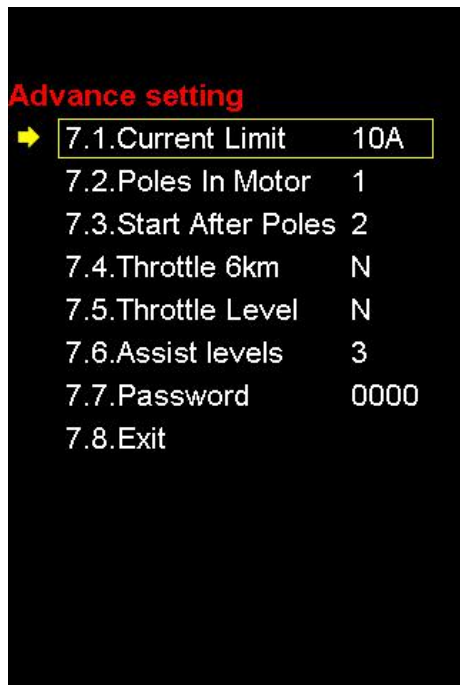

- (1) Current Limit: the range of this value is 3 - 18.
- (2) Poles In Motor: the value can be set to 1 or 6. This parameter needs to be consistent with the actual parameter of motor.
- (3) Start After Poles: the range of this value is 2 – 16.
- (4) Throttle 6KM: select **Y** and turn the throttle, enter 6KM mode, select **N** means the mode of throttle is normal.
- (5) Throttle Level: (valid when select **N** in the Throttle 6KM) **Y** means throttle with different level, **N** means throttle with one level.
- (6) Assist levels: it can be set to 3,5,6,9. If user select 3, the range of assist levels is 1-3.

(7) Password: user can set the power-on password, default no password.

The boot interface:



(8) Exit.

10.8: Information

Click **SET** enter information interface.

HW ver: Hardware version. SW ver: Software version.

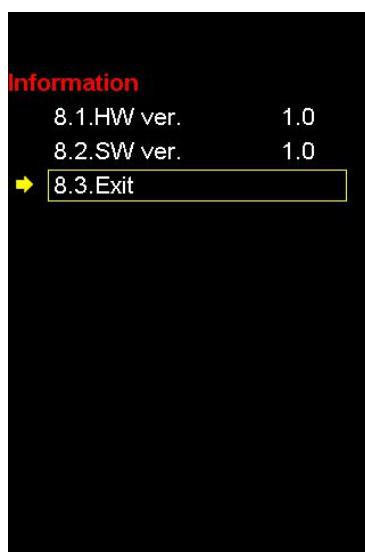

10.9: Save & Exit

Click **SET**, the set information will be saved and exit the setting interface.

11: AUTO SLEEP AFTER 5 MINUTES

When the riding speed is 0 km/h for 5 minutes, the system will go to sleep automatically.

COMMON PROBLEMS & SOLUTIONS

Q: Why the display is not able to start up?

A: Checking the connector that between display and controller.

Q: How to deal with the error code?

A : Fix it to the maintenance place immediately. If cannot be resolved, you can go to the electric vehicle repair points repair it in a timely manner.

QUALITY & WARRANTY

QUALITY & WARRANTY:

- 1、 Any quality problems in normal case and in guarantee period, our company will responsible for the warranty.
- 2、 The warranty time is 18 months from date of purchasing.

OTHER ITEMS:

The following items are not belong to warranty scope.

1. It can not be demolished.
2. The damage caused by wrong installation or operation.
3. Shell is broken when display is out of the factory.
4. Wire is broken.

5. Force disaster (such as fire, earthquake, etc.) or natural disasters like lightning, etc caused by fault or damage.
6. Beyond Warranty period.

ERROR CODE TABLE

The error code is corresponding with the fault definition.

Error code	definition
0	normal
1	Current error or MOS damaged
2	Throttle error(Start detection)
3	motor no phase position
4	Hall error
5	Brake error(Start detection)
6	Under voltage
7	Motor stalling
8	communication controller receiving error
9	communication display receiving error